

# Gilian® LFS-113

Dual Mode Low Flow Air Sampler  
1–350 cc/min. Constant Pressure  
5–200 cc/min. Constant Flow

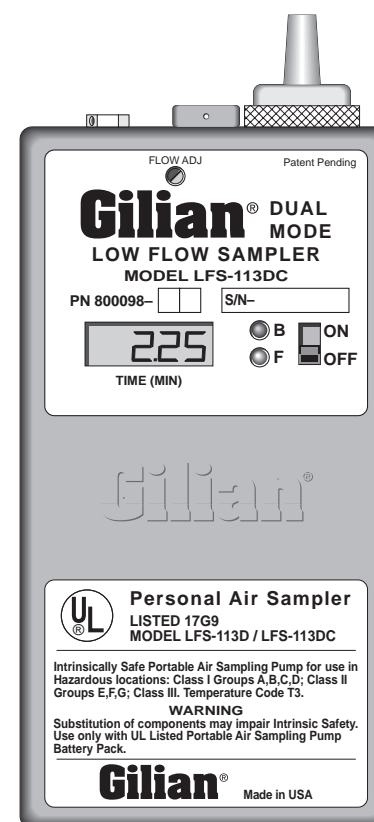

INSTRUCTION MANUAL



Certificate No. 970084

## **SENSIDYNE®**

Sensidyne, Inc.

16333 Bay Vista Drive • Clearwater, FL 33760

800-451-9444 • 727-530-3602

FAX 727-539-0550

© 1999, Sensidyne, Inc.

Document No. F-PRO-1725, Rev A

**NOTE:** Please read all warnings and instructions before operating this unit. Failure to follow these instructions and procedures can result in permanent damage to the equipment.

**WARNING:**

This unit is designed specifically for use with Gilian LFS-113, UL, and SCS intrinsically safe battery packs and equipment. The unit should only be operated in environments that the unit's intrinsic safety labeling permits. Do not operate in excessive chemical or water vapor atmospheres. Do not charge sampler outdoors or in a damp environment. Use specified Gilian chargers only when recharging the battery system. Use of any other charger may short out the battery or cause permanent damage to the electrical system. Do not leave unit charging for more than 16 hours. Overcharging cells may cause overheating and subsequent damage to/or decrease in battery life and performance.

## 6.0 SPECIFICATIONS

**Operating Range:** Constant flow mode: 5-200 cc/min., back pressures to 25" H<sub>2</sub>O  
Constant pressure mode: (multi-tube) 1-350 cc/min. with flows adjustable through a single or multiple tube flow controller.

**Pressure Range:** backpressure up to 25" H<sub>2</sub>O

**Flow Control:** ± 5% of set point

**Battery System:** Rechargeable, plug in, 4.8V, 500 mAh Ni-cad battery pack. Designed to meet all UL requirements. Internal charging, (external charging with adapter).

**Size:** 2-1/2" W x 1-3/8" H x 4-5/8" L

**Weight:** 12 ounces

**Temperature:** *Operating:* -20° to 45 c°, *Storage:* -40° to 45 c°, *Charging:* 5° to 45 c°

**Additional features:** Flow fault indication LED, battery check LED, belt clip, dual filtration system, sorbent tube end breaker, external flow adjust.

**Options:** Elapsed timer clock module: (offered on DC models), LCD display and automatic instant-fault shut-down function, RFI shielding case.

**Warranty:** The LFS-113 dual mode low flow sampler is guaranteed for one year against any defects in parts and/or workmanship.

***SENSIDYNE***<sup>®</sup>

Sensidyne, Inc.

16333 Bay Vista Drive • Clearwater, FL 33760

800-451-9444 • 727-530-3602

FAX 727-539-0550

**Figure 7**  
LFS-113 Sampler

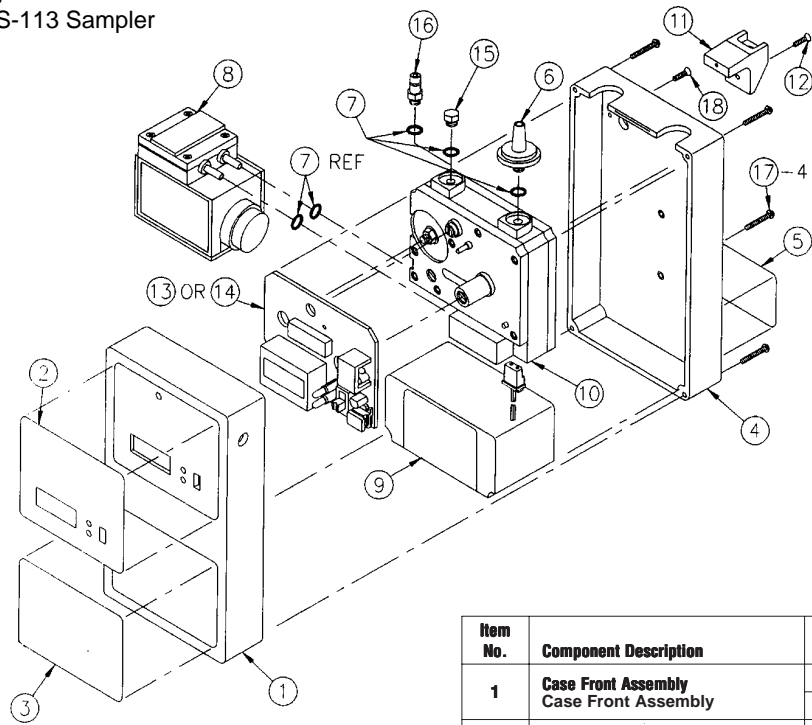

Item No.	Component Description	Part No.
1	Case Front Assembly	800091 (Std)
	Case Front Assembly	800091-3 (RFI)
2	Nameplate, LFS-113 D	400294
2A	Nameplate, LFS-113 DC	400257
3	Nameplate, UL	400258
4	Case Rear Assembly	800092 (Std)
	Case Rear Assembly	800092-1 (RFI)
5	Nameplate, MSHA	400259
6	Inlet, Filter	800093
7	O-Ring	1970-007
8	Pump Assembly	800090
9	Battery Pack Assembly	800086
10	Controller Assembly	800089
11	Tube Breaker Assembly	800497
12	Scr. Phil. Flat Hd. 2-56 x 5/16" Lg.	5258-0205
13	Control Board w/Display	400214
14	Control Board No Display	400214-1
15	Discharge Plug Assembly	800107
16	Discharge Air Boss Assembly	800108
17	Scr. Phil. Pan Hd. 2-56 x 3/4" Lg.	6075-0212
18	Scr. Phil. Flat Hd. 2-56 x 1/4" Lg.	5258-0204
---	LFS-113 D Assembly, Complete	800088
---	LFS-113 D Assembly, Complete	800088-3
---	LFS-113 DC Assembly, Complete	800098
---	LFS-113 DC Assembly, Complete	800098-3
---	Instruction Manual	F-PRO-1725

# Operating manual for the LFS-113 Air Sampling System

Includes models:  
LFS-113D, LFS-113DC

## Table of Contents

Sec.	Title	Page
	<b>WARRANTY/SERVICE INFORMATION</b>	2
	Fig. 1 - Flow/Timing Capabilities/Approvals	4
1.0	<b>INTRODUCTION</b>	5-8
	1.1 Theory of Operation	5
	1.2 General Description, nomenclature	6
	Fig. 2 - Sampler front, side & top	7
	Fig. 3 - Sampler back & side	8
2.0	<b>SET-UP</b>	9
	2.1 Charging	9
	2.2 Filter Check	9
3.0	<b>OPERATION</b>	9-12
	3.1 Mode Selection	9-10
	3.2 Constant Flow Sampling	10-11
	3.3 Multiple Flow Sampling	11-12
4.0	<b>PERFORMANCE CHECKS</b>	12-13
	4.1 Constant Flow Check	12
	4.1.1 Pressure Fault Check	12
	4.1.2 Pressure Fault Clear Check	12-13
	4.1.3 Battery Performance Check	13
	4.2 Constant Pressure	13
	4.2.1 Constant Pressure Check	13
5.0	<b>MAINTENANCE</b>	13-14
	5.1 Battery Charging and Storage	13-14
	5.2 Replacing the Battery	14
	5.3 Changing the Pump Filter	14
	Fig. 4 - Constant flow mode set-up	15
	Fig. 5 - Multi-flow mode set-up	16
	Fig. 6 - Pump test set-up	17
6.0	<b>SPECIFICATIONS</b>	18

**Figure 1**  
Flow/Timing Capabilities/Approvals

Model Designation	LOW FLOWS		TIMING	Instant Fault Function	Sorbent Tube Breaker
	Constant Flow	Constant Pressure	Elapsed Time Clock		
D	•	•			•
DC	•	•	•	•	•

**INTRINSIC SAFETY APPROVALS**

See product labeling for specific intrinsic safety approvals.

**UL** ® (Underwriters Laboratories, Inc.)

All LFS-113 series pumps are UL approved intrinsically safe for use in hazardous locations Class I, Groups A, B, C, & D, Class II, Groups E, F, & G and Class III.

UL listed 17G9, Temperature Code T3C.

**MSHA** ® (Mine Safety and Health Administration)

The designs of this air sampling pump meets the requirements of title 30 code of Federal Regulations Part 18 and are hereby approved as permissible for use in gassy mines, when used with a specified Gilian Battery pack

**SCS** ® (SIRA Certification Service), Europe

Certificate No. Ex90C2011X, Coding: EEx iB IIC T4

**ISO 9002 Quality Assurance Standard**, International

All Gilian products are designed, manufactured and produced in accordance with and comply with the ISO 9002 international quality assurance standard.

**Figure 6**  
Pump calibration/diagnostics set-up

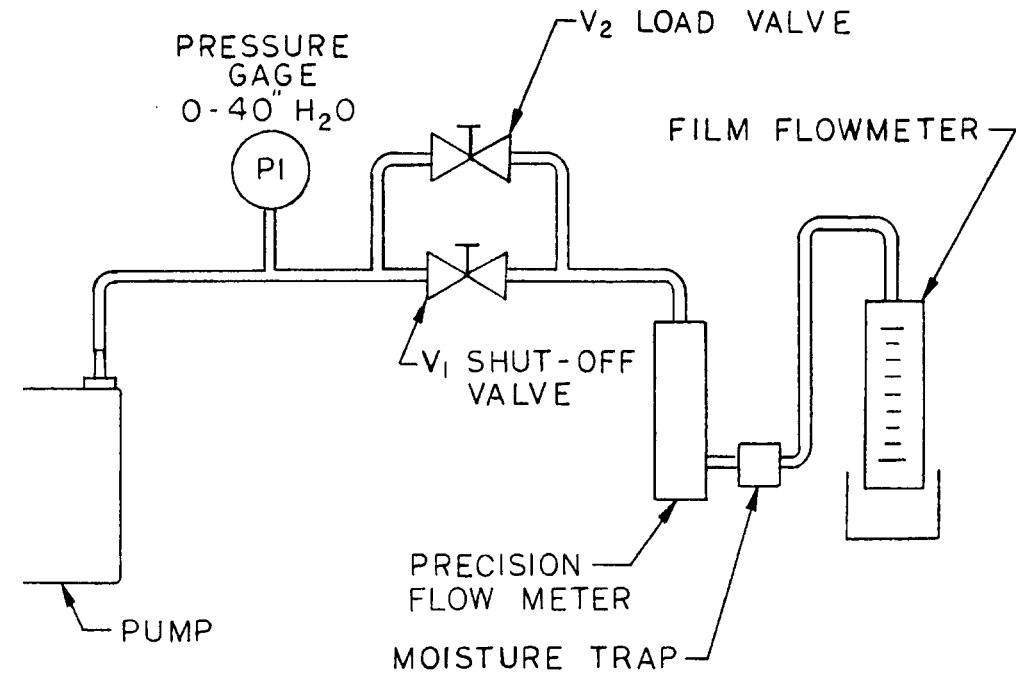

**Figure 5**  
"Constant-pressure" mode  
for multi-tube sampling

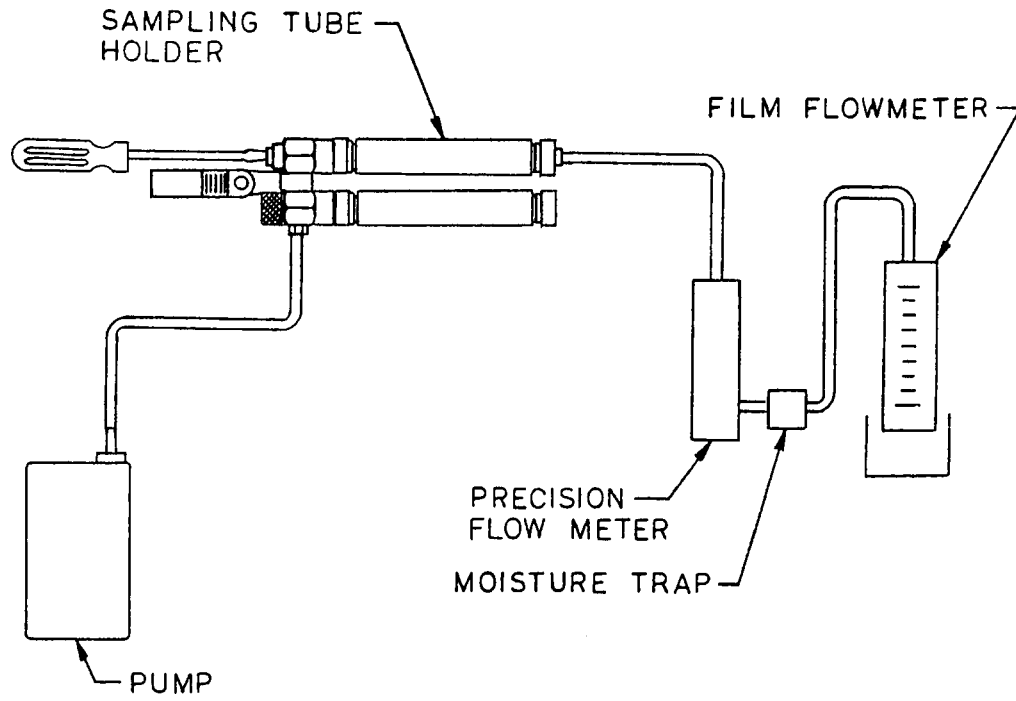

## 1.0 INTRODUCTION

The LFS-113 series sampler provides a rugged, reliable and compact sampling system for industrial hygiene and environmental sampling employment of single or multiple sorbent tubes and gas sampling bags. Two low flow modes of sampling allow constant flows from 5-200 cc/min., as well as constant pressure for multiple sorbent tube sampling from 1-350 cc/min. (combined flow rates). A compact and lightweight sampler, the LFS combines convenience and useful functions for accurate sampling.

### 1.1 Theory of Operation

The LFS low flow sampler offers two modes of sampling which are easily activated by turning the selector dial located at the back of the sampler. A hex wrench is inserted and turned to the desired position and a visual indicator displays the mode being used. The sampler is turned on and will run continuously until manually shut down. An optional LCD clock is available on DC models which offers elapsed run time and an instant-fault function. The constant pressure (multi-flow) mode when used with a multiple flow controller tube holder, offers a multi-tube sampling capability that is adjusted individually at each tube position.

## 1.2 General Description (see figures 2 and 3)

Item	Nomenclature	Description
1	<b>Charging Jack</b>	Receptacle provides means of connecting charger for recharging internal battery pack.
2	<b>Pump Filter</b>	10 Micron Nylon filter protects pump assembly from dirt. Discoloration indicates need for filter replacement.
3	<b>Mode Indicator</b>	Visually confirms mode engagement via Black or White indication.
4	<b>Mode Select</b>	Provides means of unlocking, indexing and re-locking mode selector valve to change from constant low flow to the multiple low flow mode.
5	<b>On/Off Switch</b>	Activates sampler operation.
6	<b>Battery Check</b>	Green LED indicates sufficient battery power to run the pump for an 8-hour period under normal load conditions.
7	<b>Fault Indicator</b>	Indicates flow fault due to excessive pressure or insufficient battery voltage to maintain flow.
8	<b>Clock Display</b> (DC models only.)	Indicates continuous run-time in minutes which will lock in the sample time upon fault indication. Time will reset to zero when the power switch is turned OFF and back ON.
9	<b>Flow Adjust</b>	Provides external means of adjusting the air flow rate.
10	<b>Inlet Boss</b>	Air inlet is located on the clear filter housing and provides built-in means of attaching tubing for suction sampling.
11	<b>Outlet Port</b>	Receptacle for discharge air boss accessory. The cap screw prevents dirt from entering the dischargeoutlet when not in use.
12	<b>Discharge Boss</b>	An accessory which when installed into the discharge outlet, provides a means of filling air sampling bags.
13	<b>Belt Clip</b>	Built-in means of attaching sampler to worker's belt.
14	<b>Case Screws (4)</b>	Holds battery pack in place as well as case front and back.
15	<b>Battery Pack</b>	Provides DC power to operate the unit.

**Figure 4**  
"Constant-flow" mode set-up

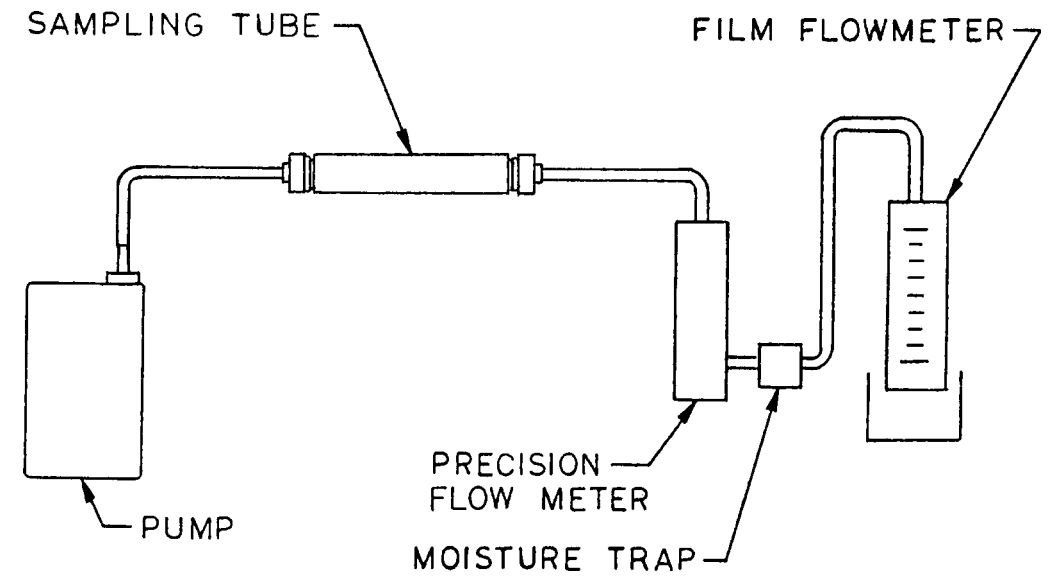

scheduled to be used for long periods of time, (more than 2 months), it is recommended that the following procedure be followed on a periodic basis.

- a) Run pumps until they shut down on low battery.
- b) Recharge the battery overnight (16) hours and return the pumps into storage.

### 5.2 Replacing the Battery: (refer to figure 7)

Place the sampler face down on a soft, level surface. Remove the four corner case screws. Supporting the pump by the front half, turn the sampler face up. Remove the top half to reveal the internal mechanism. Disengage the Battery Connector from the receptacle located on the Control Board (13 or 14). Lift the battery pack (9) from the base of the case. To install a new battery, reverse this procedure. **NOTE:**The connector is polarized and can only be properly installed in one direction.

### 5.3 Changing the Pump Filter: (refer to figures 2 and 7)

Under normal operating conditions, the pump filter should be changed after approximately 250 hours of operation or when needed. Failure to change the filter as it becomes dirty will decrease the pump's back pressure capability and performance envelope.

Blow all dust and debris from around the Filter Housing (2). Grasp the knurled edge of the filter housing assembly and rotate counter-clockwise. Check the new filter housing assembly to make sure that the sealing "O" ring is present on the internal boss. Install the new Filter Housing Assembly onto the pump rotating the knurled edge clockwise. **Do Not Overtighten!** Check the filter's performance by using the Constant Pressure Check, (see Section 4.2.1).

**Figure 2**  
LFS-113 Air Sampler  
General Description, front, side & top

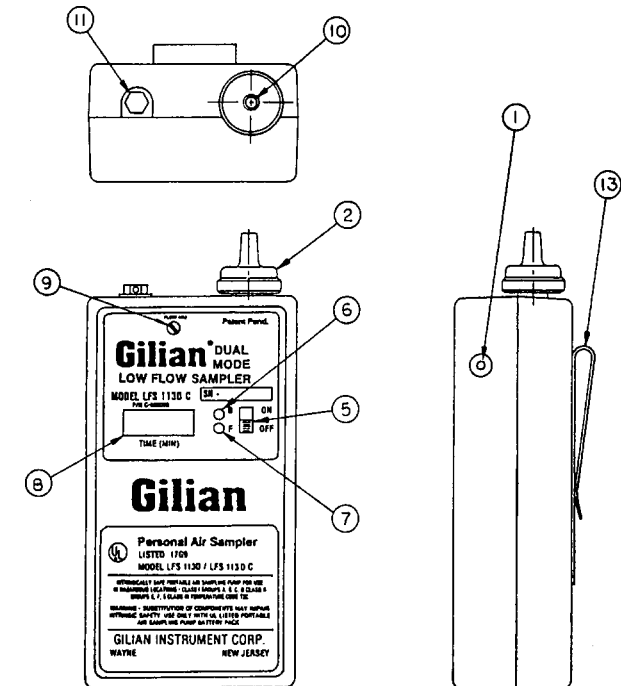

1. Charging Jack
2. Inlet Filter Assy.
5. On/Off Switch
6. Battery Check Indicator
7. Fault Indicator
8. Clock Display
9. Flow Control Valve
10. Inlet Boss
11. Outlet Port/Cap
13. Belt Clip

**Figure 3**  
**LFS-113 Air Sampler**  
**General Description, back & side**

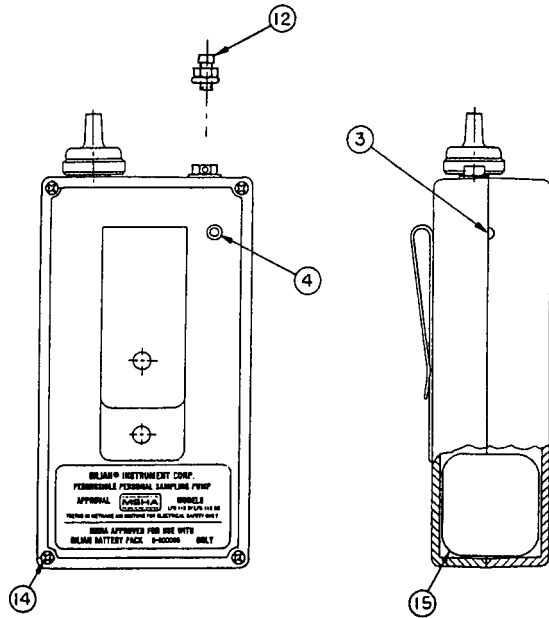

- 3. Mode Position Indicator
- 4. Mode Selector Switch
- 12. Bag Sampling Boss
- 14. Case Screws (4)
- 15. Battery Pack

#### 4.1.3 Battery Performance Check:

Allow the unit to run down until the pump shuts off. Monitor the flow periodically, either visually or by means of an electronic flow recorder with chart readout. The flow should not change by more than 5% prior to fault activation and automatic pump shutdown due to low battery voltage.

As an alternate means of checking the pump low battery performance, remove the battery pack from the battery connection receptacle of the control board electronics. Provide an external DC voltage supply to the Control Board battery receptacle. Slowly decrease the voltage from 4.8 volts to 4.4 volts. The flow should not change by more than 5% prior to fault activation and automatic pump shutdown due to low battery.

#### 4.2 Constant Pressure:

##### 4.2.1 Constant Pressure Check:

Switch the sampler into the "Constant-pressure" mode, (see Section 3.1 for complete indexing procedure). Attach the pump into the test set-up as shown in figure 6. If you are using the Gilian LIHCP calibrator: close the shut off valve (V1). Close Load Valve (V2). Observe the pressure on the magnehelic gauge (P1). That pressure should be 18" H<sub>2</sub>O, ± 2%. Slowly open the Load Valve (V2) until the flow is approximately 400 cc/min. The pressure on Magnehelic gauge (P1) should change by no more than 2 inches. (If a greater pressure change is indicated, it is possible that the sampler's external filter assembly is contaminated and needs replacement.)

#### 5.0 PUMP MAINTENANCE (see figures 1 & 5)

Your LFS sampler has been designed to require minimum maintenance. However, the following sections cover the basic procedures to maintain trouble free operation and optimum performance.

##### 5.1 Battery Charging and Storage Maintenance:

A proper battery maintenance program is essential to insure maximum battery life and performance. Specific charging and discharging procedures will vary with the users needs and/or applications. The following is a list of general recommendations which will help to extend efficient battery life and serviceability.

1. Do not short the battery connectors. This may result in severe damage to the battery pack.
2. Do not overcharge the battery pack. You should not charge battery packs at the "Normal" (constant current) rate for more than 24 hours. Repeated overcharging will eventually lead to deterioration in the performance level of the battery pack. If you must have batteries charging for more than 24 hours, we recommend that you switch the charger into "Trickle" (pulse current) mode. This feature is available on all Gilian DRC and ATR version chargers.
3. The long term storage of pumps will require some special handling. If pumps are not



cannot exceed 350 cc/min. After the flow of each position has been set, check that no flow interactions have occurred. If there has been a deviation at one particular position, go back to each cassette and readjust the flow.

The unit can now be removed from the rotameter and prepared for sampling. In the "Constant-pressure" mode, blocking any one or all of the sorbent tube inlets, will not cause the sampler to flow fault. However, if the battery voltage falls below the operating point required, the Fault Indicator (7) will light and the unit will cease running.

## 4.0 PERFORMANCE CHECKS

### 4.1 Constant Flow Performance Check

Make sure that the pump is in the "Constant-flow mode, (*refer to Section 3.1 for complete mode selection procedure*). A simple method of quickly checking constant flow performance is provided by Gilian's Low Flow Industrial Hygiene Calibrator Pack (LIHCP).

Attach the pump into the LIHCP or similar calibration set-up, (*see figure 6*). If you are using the LIHCP calibrator: open the shut off valve (V1). Turn the sampler ON. Adjust the sampler flow by inserting a small blade screwdriver into the pump's recess marked Flow Adjust (9). Engage the blade of the screwdriver with the slot of the Flow Control Valve and slowly rotate the valve clockwise to decrease flow or counter-clockwise to increase flow. Observe the reading on the rotameter. If a precision reading is required, a film flowmeter must be used.

Close shut-off valve (V1) and adjust load valve (V2) to 20" H<sub>2</sub>O. Allow sufficient time for the flow to reach stability. **NOTE:** If very low flows are being used, please allow several minutes time for stabilization. Check the reading on the rotameter or the film flowmeter if one is being used. Accuracy can be determined by taking the difference in flows over the original set point. The deviation should be less than 5%. Reopening the shut-off valves allows rechecking the initial set point.

#### 4.1.1 Pressure Fault Check:

Using the same test set up as shown in *figure 6*, adjust load valve (V2) so that the pressure on the magnehelic gauge (P1) exceeds 25-30" H<sub>2</sub>O. After 3-5 minutes the Fault Indicator (7) will light indicating an excessive pressure condition. Approximately 20 to 40 seconds later, the unit will cease running and the time will be latched and indicated on the Clock Display (8) - (*DC models only*). The fault can be cleared and re-set (opening the load valve) by turning the Power Switch OFF and then back ON again.

#### 4.1.2 Pressure Fault Clear Check:

Adjust load valve (V2) again so that the pressure exceeds 25-30" H<sub>2</sub>O. The Fault indicator will light, indicating an excessive pressure condition. Slowly reduce the load pressure. The Fault Light will extinguish at a pressure below 20" H<sub>2</sub>O and the pump will continue to operate normally.

## 2.0 OPERATION SET-UP

### 2.1 Charging the LFS-113: (*refer to figures 2 and 3*)

Plug a Gilian dual-rate charger into a properly grounded AC outlet. Set the charging rate select switch to the "Normal" mode. Insert the charging jack into the sampler's Charging Receptacle (1), located on the side of the pump. Upon insertion, the "Normal" rate LED on the charger will light indicating active charging of the battery pack.

Charge the battery for a minimum of 16 hours at the "Normal" rate. After 16 hours the sampler may be removed from the charger and utilized. If the sampler must remain on charge for longer than 16 hours, the charger should be switched over to the "Trickle" charge mode. Charging in accord with the above instructions will prolong battery life. Failure to follow these instructions may cause deterioration and permanent damage to the battery pack.

### 2.2 Filter Check:

Make sure that the Inlet Filter Assembly (2) is secured into the suction Inlet Boss (10). Check this by rotating the knurl on the bottom of the Filter Assembly clockwise. **Do Not Overtighten.**

## 3.0 Operation

The LFS-113 is a dual mode sampler, providing low flow air sampling in Constant Flow or Constant Pressure (multiple flow) modes. In the "Constant-flow mode, the unit is externally set from 5-200 cc/min. by adjustment of the Flow Control Valve (9). In the "Constant-pressure" mode, the unit is externally set from 1-350 cc/min. by means of the Flow Controller Valve(s) within the Flow Controller Tube Holder Assembly.

A green Battery Check LED Indicator (6) lights to show that the battery will run for a minimum of eight (8) hours at any flow regime within the unit's capability. A red Flow Fault LED Indicator (7) is actuated by either a blocked inlet condition or insufficient battery voltage to maintain the preset flow.

### 3.1 Mode Selection:

The Mode Selector Switch (4) is located on the back of the sampler, adjacent to the top of the Belt Clip. This unlocks, indexes and re-locks the Mode Selector Valve into one of the Dual sampling modes.

The Mode Indicator (3) is observable through a hole in the side of the case. If the indicator is black, then the unit is in the "Constant-Flow" mode. If the indicator is light or white, then the unit is in the "Constant-Pressure" mode (multi-flow sampling).

To set the LFS pump into one of the sampling modes, insert the Allen Key, ("L"-shaped hex wrench) provided with the sampler, into the Mode Selector Switch (4). Rotate the key counter-clockwise to unlock the rotor. Continue rotating the key counter-clockwise approximately one half a turn until the switch clicks in.

Look into the mode indicator window on the side of the sampler to see that the indicator is black or white, depending on the mode desired. Continue turning the selector switch counter-clockwise until the desired mode has been set. Now, lock the rotor into position by rotating the key clockwise - a half turn. Tighten Gently - **Do Not Overtighten!**

The samplers mode indicator will have appeared either black for "Constant-Flow" or white for "Constant-Pressure". Turn the pump ON. To check if the pump is in "Constant-flow mode, hold your finger over the Pump Inlet Boss (10), the samplers Fault Light will illuminate in approximately 3-5 seconds. This signal means that the sampler is operating properly in the "Constant-flow mode. NOTE: If the pump is set at a very low flow (i.e., 10 cc/min.), it may take 10 seconds for the Fault Indicator LED (7) to illuminate.

### 3.2 Constant Flow Sampling:

First, make sure that the pump is in the Constant-flow mode. If needed, follow the procedures explained in Section 3.1 to achieve the "Constant-flow" mode.

Connect one end of the 1/8" ID tubing to the Pump Inlet Boss (10) and the opposite end to the inlet boss of the Flow Controller Tube Holder Assembly.

**NOTE:** Each LFS-113D-DK & DC-DK kit comes equipped with a special Dual Manifold Tube Holder Kit (B-800148). This kit was designed to sample two (2) standard 6mm x 70mm sorbent tubes when used in the "Constant-pressure" mode. However, when sampling in the "Constant-flow" mode, you may use only one (1) Sorbent Tube Cassette.

Unscrew one of the tube cassettes from the Flow Controller Manifold. Remove one Tube Holder End (p/n 800062) and slip the Collar Clip (800135) over the Tube Holder Housing (200102). Install the desired sorbent tube with the arrow, (printed on the tube) pointing in the direction of the air flow path. Replace the end and insert the additional Hose Barb Fitting (800170). Connect the tubing from the Pump Inlet Boss (10) to the Hose Barb on the end of the tube holder cassette.

For complete instructions, please refer to the instruction sheet for the "Universal Tube Holder System", (Form no. FPRO-1218).

Turn the sampler ON. The sampler will run and the green Battery Check LED (6) will illuminate indicating that the sampler can be used for 8 hours under maximum load conditions. (If the green light does not illuminate, the sampler may still be capable of running for an eight (8) hour period, if not subjected to maximum load conditions).

**NOTE:** During normal sorbent tube sampling, the LFS system is used at approximately 50% of its maximum capacity.

Setting flow in the "Constant-flow" mode is accomplished by adjusting the flow adjust valve located on the front of the sampler. To set the flow, connect a piece of 1/8" ID tubing from the inlet of the Flow Controller Tube Holder, to the suction side of a low range rotameter, (see figure 4). Adjust the flow by inserting a small blade screwdriver into the recess marked Flow Adjust (9) - engage the blade of the screwdriver with the slot of the Flow Adjust Valve and slowly rotate the valve clockwise to decrease flow or counter-clockwise to increase flow.

Once the flow has been established, allow the sampler to run for approximately one minute to reach flow stability. A quick check of the fault system should be performed by blocking the inlet to the pump and observing the activation of the Fault Indicator (7). Maintaining the blockage for 20-40 seconds will cause the pump to cease and the time to latch. If the blockage is removed prior to completion of the fault time activation period, the light will extinguish and the pump will continue to run normally.

### 3.3 Multiple Flow Sampling:

Set the Mode Select Switch (4) to the "Constant-pressure" mode, (see Section 3.1 for complete Mode Selection procedure). In this mode, the internal control valve is inoperative.

Attach the 1/8" ID tubing to the Flow Controller Manifold outlet boss (single, dual, triple or quad), (see figure 5). Connect the opposite end of the tubing to the boss of the Pump Inlet Filter (2). Remove the protective end caps covering the Flow Adjust Valves of the Flow Controller Manifold. Install the desired sorbent tube(s) with the arrow, (printed on the tube) pointing in the direction of the air flow path. Reassemble each sorbent tube cassette and install a boss into the tube holder end of each cassette position if necessary. **NOTE:** For complete tube holder assembly instructions, please refer to the "Universal Tube Holder System" sheet for description and set-up.

Turn ON the sampler. The sampler will run and the green Battery Check LED (6) will illuminate indicating that the sampler can be used for eight (8) hours under maximum load conditions. (If the green light does not illuminate, the sampler may still be capable of running for an eight (8) hour period, if not subjected to maximum load conditions).

**NOTE:** During normal sorbent tube sampling, the LFS system is used at approximately 50% of its maximum capacity.

Connect a second piece of 1/8" ID tubing from the inlet boss of a sorbent tube cassette position, to a rotameter, (see figure 5). Adjust the flow through the sorbent tube by adjusting the Flow Control Valve located at that cassette position. Slowly rotate the valve clockwise to decrease flow or counter-clockwise to increase flow.

Repeat this procedure for each of the sorbent tube holder positions by removing the tubing from the inlet boss and reattach to the inlet boss of the next desired cassette position. **NOTE:** In the "Constant-pressure" mode, the total cumulative flow of all the flow controller valves,